

Werkzeughänger
Tool hanger



Arbeitsleuchten
Workstation Lamps

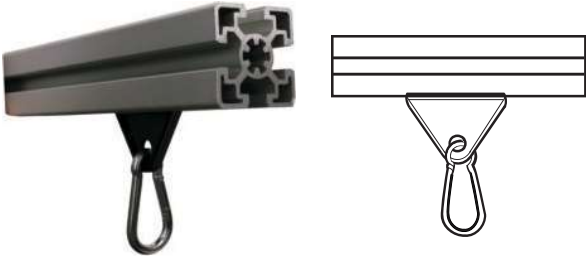

Werkzeughänger, Arbeitsleuchten
Tool hanger, Workstation Lamps

		Allgemein	General
		Anwendung WKZ-Hänger für verschiebbare Werkzeugaufhängungen mit Option zur sicheren Fixierung in einer Position	Application Sliding tool hanger for balancers with option to lock into fixed position

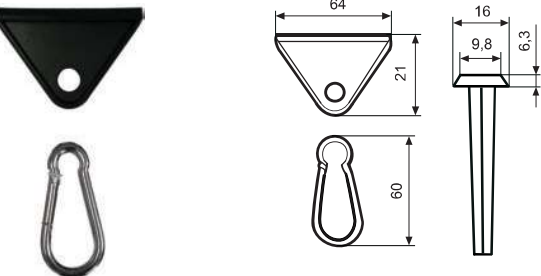
102 019 002	Werkzeughänger	Tool hanger	
	Stückzahl/Box	Quantity/box	20
	Gewicht/Setzen	Weight/set	36g
	Gewicht/Box	Weight/box	0,72kg
	Material Polyoxymethylen (POM), schwarz Haken: Stahl	Material Polyoxymethylene (POM), black; Hook: Steel	
	Vorteile Preisgünstig und einfach	Advantages Inexpensive and easy-to-use	

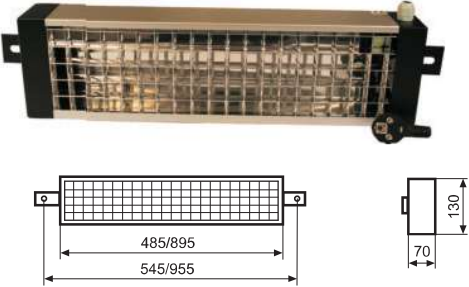
102 022 ...	Arbeitsleuchte	Workstation lamp	
2x36 Watt: 001 1x36 Watt: 002 2x36 Watt (Electronic): 003 	Stückzahl/Box	Quantity/box	1
	Gewicht, lang	Weight, long	4,5kg
	Gewicht, kurz	Weight, short	3kg
	Zertifizierung	Certification	TÜV, CE
	Kabel mit Stecker	Power cable/plug	3m
	Anschlussspannung	Voltage	230V
	Anschlussfrequenz	Connection frequency	50Hz
	Inklusive Leuchtmittel	Inclusive lightening	1x/2x 2900 lm
	Blendfrei, durchschnittlich 750lx bei Arbeitsfläche 1,4x0,8m und 1m Distanz	Anti-glare, average 750lx on table top 1.4x0.8m and 1m distance	DIN 5035-T2\ EN12464-1
	Elektronische Leuchte: flickerfrei längere Lebensdauer geringerer Energieverbrauch	Electronic lamp: flicker-free longer lifetime low power consumption	