

## Winkel Brackets

Allgemein	General
-----------	---------

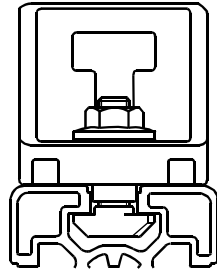

**Material**  
Aluminiumdruckguss  
blanke Oberfläche

**Anwendung**  
Zur rechtwinkligen Verbindung  
von Profilen

**Vorteile**  
Kein Bohren nötig,  
verstellbar

**Material**  
Die cast aluminium  
plain surface

**Application**  
To connect profiles and  
panels rectangularly

**Advantages**  
No tapping, adjustable

2

102 002 702	↻ 5 Nm	Winkel 20x20	Bracket 20x20	
-------------	--------	--------------	---------------	--

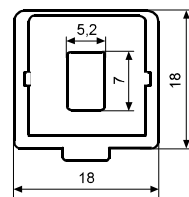

Stückzahl/Box  
Gewicht/Stk.  
Gewicht/Box  
Max. Belastung  
Biegemoment

Quantity/box  
Weight/pc  
Weight/box  
Max. load  
Bending moment

100  
10g  
1,0kg  
700N  
6Nm

Zubehör nicht inkl.:  
2 x Hammermutter  
2 x Schraube  
1 x Abdeckkappe

Accessories not incl.:  
2 x T-Nut Slot 6 M4  
2 x Screw M4x8  
1 x Cover cap

**102 010 018**  
**102 009 005**  
**102 032 700**



102 002 001	↻ 10 Nm	Winkel 30x30	Bracket 30x30	
-------------	---------	--------------	---------------	--

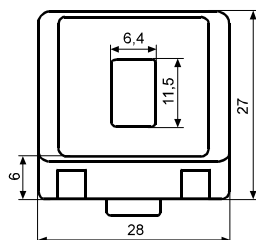

Stückzahl/Box  
Gewicht/Stk.  
Gewicht/Box  
Max. Belastung  
Biegemoment

Quantity/box  
Weight/pc  
Weight/box  
Max. load  
Bending moment

100  
20g  
2,0kg  
1250N  
25Nm

Zubehör nicht inkl.:  
2 x Hammermutter  
2 x Schraube

Accessories not incl.:  
2 x T-Nut Slot 8 M6  
2 x Screw M6x12

**102 010 006**  
**102 009 002**



102 002 002	↻ 10 Nm	Winkel 30x60	Bracket 30x60	
-------------	---------	--------------	---------------	--

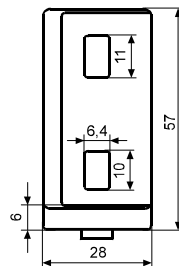

Stückzahl/Box  
Gewicht/Stk.  
Gewicht/Box  
Max. Belastung  
Biegemoment

Quantity/box  
Weight/pc  
Weight/box  
Max. load  
Bending moment

10  
58g  
0,58kg  
2500N  
100Nm

Zubehör nicht inkl.:  
4 x Hammermutter  
4 x Schraube

Accessories not incl.:  
4 x T-Nut Slot 8 M6  
4 x Screw M6x12







**102 010 006**  
**102 009 002**





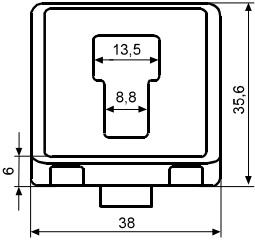



1 x Cover cap





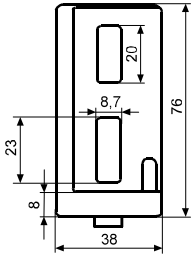

**102 032 710**

## Winkel Brackets

Winkel 40x40	Bracket 40x40		 25 Nm	102 002 003
Stückzahl/Box	Quantity/box	100	 	
Gewicht/Stk.	Weight/pc	33g		
Gewicht/Box	Weight/box	3,3kg		
Max. Belastung	Max. load	3000N		
Biegemoment	Bending moment	55Nm		
Zubehör nicht inkl.:	Accessories not incl.:			
2 x Hammerschraube	2 x T-Bolt M8x20	102 010 002		
2 x Flanschmutter	2 x Flange nut	102 010 003	 <b>55 Nm</b>	 <b>3000 N</b>
1 x Abdeckkappe	1 x Cover cap	102 032 002		

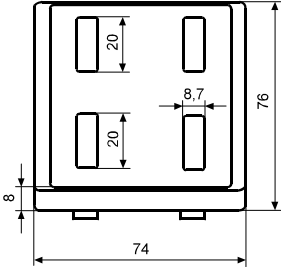
2

Winkel 40x80	Bracket 40x80		 25 Nm	102 002 004
Stückzahl/Box	Quantity/Box	10	 	
Gewicht/Stk.	Weight/pc	122g		
Gewicht/Box	Weight/Box	1,22kg		
Max. Belastung	Max. load	6000N		
Biegemoment	Bending moment	180Nm		
Zubehör nicht inkl.:	Accessories not incl.:			
4 x Hammerschraube	4 x T-Bolt M8x25	102 010 001		
4 x Flanschmutter	4 x Flange nut	102 010 003	 <b>180 Nm</b>	 <b>6000 N</b>
1 x Abdeckkappe	1 x Cover cap	102 032 704		

Winkel 80x80	Bracket 80x80		 25 Nm	102 002 705
Stückzahl/Box	Quantity/box	10	 	
Gewicht/Stk.	Weight/pc	225g		
Gewicht/Box	Weight/box	2,25kg		
Max. Belastung	Max. load	12000N		
Biegemoment	Bending moment	370Nm		
Zubehör nicht inkl.:	Accessories not incl.:			
8 x Hammerschraube	8 x T-Bolt M8x25	102 010 001		
8 x Flanschmutter	8 x Flange nut	102 010 003	 <b>370 Nm</b>	 <b>12000 N</b>
1 x Abdeckkappe	1 x Cover cap	102 032 707		

## Winkel Brackets

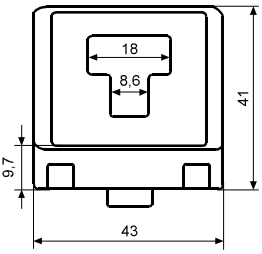

**102 002 005**      **25 Nm**      **Winkel 45x45**      **Bracket 45x45**      





Stückzahl/Box	Quantity/box	100
Gewicht/Stk.	Weight/pc	57g
Gewicht/Box	Weight/box	5,7kg
Max. Belastung	Max. load	3000N
Biegemoment	Bending moment	60Nm

Zubehör nicht inkl. :      Accessories not incl. :

2 x Hammerschraube	2 x T-Bolt M8x25	<b>102 010 001</b>
2 x Flanschmutter	2 x Flange nut	<b>102 010 003</b>
1 x Abdeckkappe	1 x Cover cap	<b>102 032 003</b>

**2**       **60 Nm**       **3000 N**      

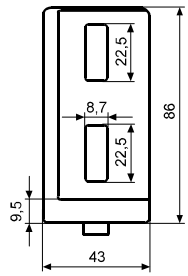

**102 002 006**      **25 Nm**      **Winkel 45x90**      **Bracket 45x90**      





Stückzahl/Box	Quantity/box	10
Gewicht/Stk.	Weight/pc	162g
Gewicht/Box	Weight/box	1,62kg
Max. Belastung	Max. load	6000N
Biegemoment	Bending moment	180Nm

Zubehör nicht inkl. :      Accessories not incl. :

4 x Hammerschraube	1 x T-Bolt M8x20	<b>102 010 001</b>
4 x Flanschmutter	4 x Flange nut	<b>102 010 003</b>
1 x Abdeckkappe	1 x Cover cap	<b>102 032 709</b>

 **180 Nm**       **6000 N**      

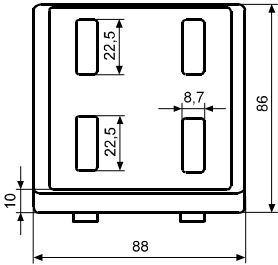

**102 002 008**      **25 Nm**      **Winkel 90x90**      **Bracket 90x90**      













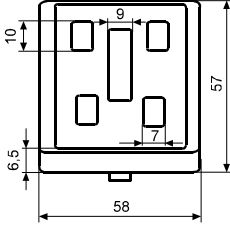



Stückzahl/Box	Quantity/box	10
Gewicht/Stk.	Weight/pc	333g
Gewicht/Box	Weight/box	3,33kg
Max. Belastung	Max. load	12000N
Biegemoment	Bending moment	370Nm

Zubehör nicht inkl. :      Accessories not incl. :

8 x Hammerschraube	8 x T-Bolt M8x25	<b>102 010 001</b>
8 x Flanschmutter	8 x Flange nut	<b>102 010 003</b>
1 x Abdeckkappe	1 x Cover cap	<b>102 032 706</b>

 **370 Nm**       **12000 N**      

## Winkel Brackets

Winkel 60x60	Bracket 60x60	 	102 002 007
Stückzahl/Box	Quantity/box	10	 
Gewicht/Stk	Weight/pc	105g	
Gewicht/Box	Weight/box	1,05kg	
Max. Belastung	Max. load	3000N	
Biegemoment	Bending moment	125Nm	
Zubehör nicht inkl.:	Accessories not incl.:		
 $\Rightarrow$ 			 
8 x Schraube	8 x Screw M6x12	<b>102 009 002</b>	 
8 x Hammermutter	8 x T-Nut Slot 8 M6	<b>102 010 006</b>	
 $\Rightarrow$ 			
4 x Schraube	4 x Screw M6x12	<b>102 009 002</b>	
4 x Hammermutter	4 x T-Nut Slot 8 M6	<b>102 010 006</b>	
1 x Hammerschraube	1 x T-Bolt M8x25	<b>102 010 002</b>	 
1 x Flanschmutter	1 x Flange nut	<b>102 010 003</b>	
 $\Rightarrow$ 			
2 x Hammerschraube	2 x T-Bolt M8x25	<b>102 010 002</b>	
2 x Flanschmutter	2 x Flange nut	<b>102 010 003</b>	
1 x Abdeckkappe	1 x Cover cap	<b>102 032 702</b>	

## Würfelverbinder Cubic Connectors

	Allgemein	General
--	-----------	---------

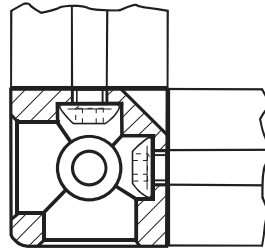

**Material**

Aluminiumdruckguss

**Anwendung**  
Zur rechtwinkligen Verbindung von bis zu drei Profilen, inkl. Abdeckkappen zum Verschließen der Öffnungen

**Vorteile**

Verdrehgesicherte Verbindung, optisch ansprechend

**Material**

Die cast aluminium

**Application**  
To connect up to three profiles rectangularly, incl. caps to cover the bores

**Advantages**

Rotation-proof connection, appealing design

2

102 007 003	<b>Würfelverbinder 20x20-2D</b>	<b>Cubic Connector 20x20-2D</b>	
-------------	---------------------------------	---------------------------------	--

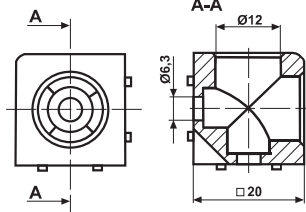

Stückzahl/Box  
Gewicht/Stk.  
Gewicht/Box  
Inkl. 2 x Abdeckkappen  
Zubehör nicht inkl.:  
2 x Schrauben M6x20

Quantity/box  
Weight/pc  
Weight/box  
Incl. 2 x cover caps  
Accessories not incl.:  
2 x Central bolt M6x20

102 007 004	<b>Würfelverbinder 20x20-3D</b>	<b>Cubic Connector 20x20-3D</b>	
-------------	---------------------------------	---------------------------------	--

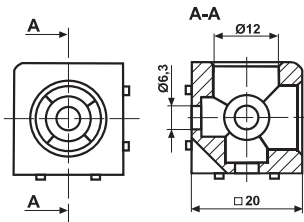

Stückzahl/Box  
Gewicht/Stk.  
Gewicht/Box  
Inkl. 3 x Abdeckkappen  
Zubehör nicht inkl.:  
3 x Schrauben M6x20

Quantity/box  
Weight/pc  
Weight/box  
Incl. 3 x cover caps  
Accessories not incl.:  
3 x Central bolt M6x20

102 007 005	<b>Würfelverbinder 30x30-2D</b>	<b>Cubic Connector 30x30-2D</b>	
-------------	---------------------------------	---------------------------------	--

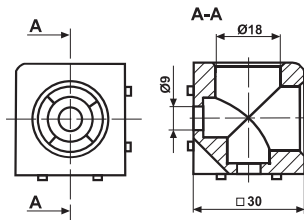

Stückzahl/Box  
Gewicht/Stk.  
Gewicht/Box  
Inkl. 2 x Abdeckkappen  
Zubehör nicht inkl.:  
2 x Schrauben M8x20

Quantity/box  
Weight/pc  
Weight/box  
Incl. 2 x cover caps  
Accessories not incl.:  
2 x Central bolt M8x20

## Würfelverbinder Cubic Connectors

### Würfelverbinder 30x30-3D Cubic Connector 30x30-3D 102 007 006

Stückzahl/Box	Quantity/box	10
Gewicht/Stk.	Weight/pc	39g
Gewicht/Box	Weight/box	0,39kg
Inkl. 3 x Abdeckkappen	Incl. 3 x cover caps	
Zubehör nicht inkl.:	Accessories not incl.:	
3 x Schrauben M8x20	3 x Central bolt M8x20	

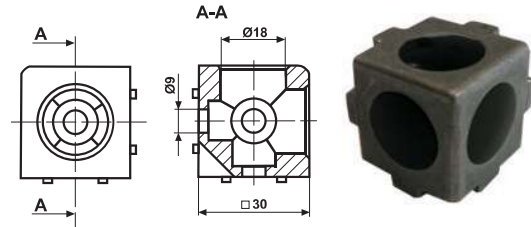

### Würfelverbinder 40x40-2D Cubic Connector 40x40-2D 102 007 007

Stückzahl/Box	Quantity/box	10
Gewicht/Stk.	Weight/pc	95g
Gewicht/Box	Weight/box	0,95kg
Inkl. 2 x Abdeckkappen	Incl. 2 x cover caps	
Zubehör nicht inkl.:	Accessories not incl.:	
2 x Schrauben	2 x Central bolt M12x30	

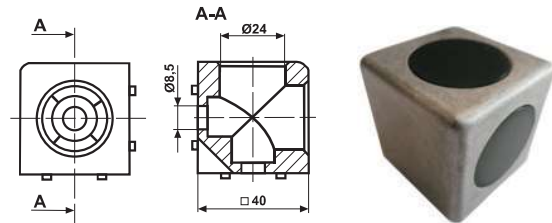

2

### Würfelverbinder 40x40-3D Cubic Connector 40x40-3D 102 007 008

Stückzahl/Box	Quantity/box	10
Gewicht/Stk.	Weight/pc	95g
Gewicht/Box	Weight/box	0,95kg
Inkl. 3 x Abdeckkappen	Incl. 3 x cover caps	
Zubehör nicht inkl.:	Accessories not incl.:	
3 x Schrauben	3 x Central bolt M12x30	

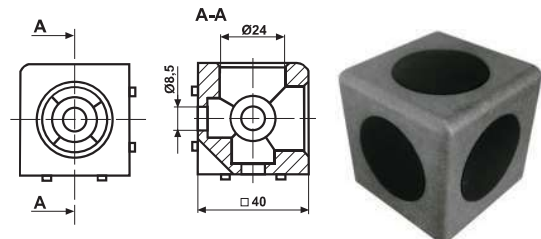

### Würfelverbinder 45x45-2D Cubic Connector 45x45-2D 102 007 009

Stückzahl/Box	Quantity/box	10
Gewicht/Stk.	Weight/pc	152g
Gewicht/Box	Weight/box	1,52kg
Inkl. 2 x Abdeckkappen	Incl. 2 x cover caps	
Zubehör nicht inkl.:	Accessories not incl.:	
2 x Schrauben	2 x Central bolt M12x30	

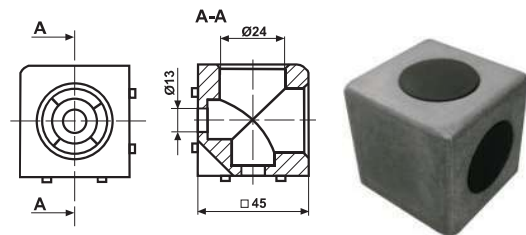

### Würfelverbinder 45x45-3D Cubic Connector 45x45-3D 102 007 010

Stückzahl/Box	Quantity/box	10
Gewicht/Stk.	Weight/pc	152g
Gewicht/Box	Weight/box	1,52kg
Inkl. 3 x Abdeckkappen	Incl. 3 x cover caps	
Zubehör nicht inkl.:	Accessories not incl.:	
3 x Schrauben	3 x Central bolt M12x30	

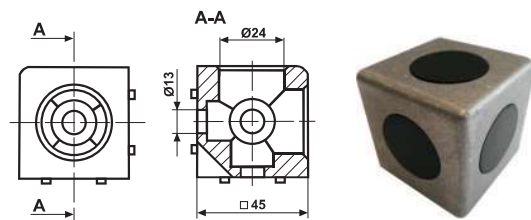

## Eckwinkel Corner Brackets

2



Allgemein	General
-----------	---------

**Material**

Aluminiumdruckguss

**Anwendung**

Zur rechtwinkligen Verbindung von drei Profilen

**Vorteile**

Verdrehgesicherte Verbindung, optisch ansprechend

**Material**

Die cast aluminium

**Application**

To connect three profiles rectangularly

**Advantages**

Rotation-proof connection, appealing design

102 007 011	Eckwinkel 20	Corner Bracket 20	
-------------	--------------	-------------------	--

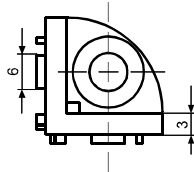

Stückzahl/Box  
Gewicht/Stk  
Gewicht/Box

Quantity/box  
Weight/pc  
Weight/box

10  
10g  
0,1kg

Zubehör nicht inkl.:

- 3 x Schrauben
- 1 x Abdeckkappe rund
- 1 x Abdeckkappe kubisch

Accessories not incl.:

- 3 x Screws
- 1 x cover cap round
- 1 x cover cap cube

102 007 710  
102 007 711



102 007 012	Eckwinkel 30	Corner Bracket 30	
-------------	--------------	-------------------	--

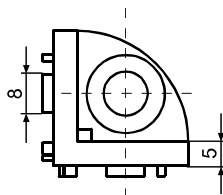

Stückzahl/Box  
Gewicht/Stk  
Gewicht/Box

Quantity/box  
Weight/pc  
Weight/box

10  
40g  
0,4kg

Zubehör nicht inkl.:

- 3 x Schrauben
- 1 x Abdeckkappe rund
- 1 x Abdeckkappe kubisch



Accessories not incl.:

- 3 x Screws
- 1 x cover cap round
- 1 x cover cap cube



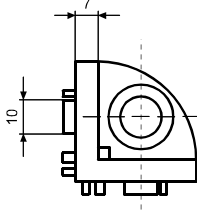

102 007 712  
102 007 713

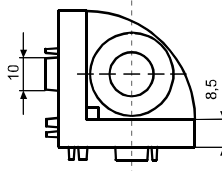

## Eckwinkel Corner Brackets

Eckwinkel 40	Corner Bracket 40		102 007 013
Stückzahl/Box Gewicht/Stk. Gewicht/Box	Quantity/box Weight/pc Weight/box	10 85g 0,85kg	 
Zubehör nicht inkl.: 3 x Schrauben 1 x Abdeckkappe rund 1 x Abdeckkappe kubisch	Accessories not incl.: 3 x Screws 1 x cover cap round 1 x cover cap cube	<b>102 007 714</b> <b>102 007 715</b>	
			

**2**



Eckwinkel 45	Corner Bracket 45		102 007 014
Stückzahl/Box Gewicht/Stk. Gewicht/Box	Quantity/box Weight/pc Weight/box	10 132g 1,32kg	 
Zubehör nicht inkl.: 3 x Schrauben 1 x Abdeckkappe rund 1 x Abdeckkappe kubisch	Accessories not incl.: 3 x Screws 1 x cover cap round 1 x cover cap cube	<b>102 007 716</b> <b>102 007 717</b>	
			

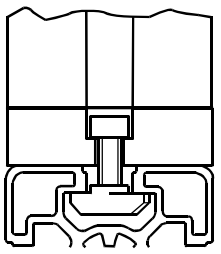

T-Verbinder  
T Connector

		Allgemein	General
		<b>Material</b> Zinkdruckguss, für Profile 45x45	<b>Material</b> Die cast zinc for profile 45x45
		<b>Anwendung</b> Zur rechtwinkligen Verbindung von 45x45-Profilen an andere Profile oder Platten	<b>Application</b> To connect profiles 45x45 rectangularly to other profiles or plates
		<b>Vorteile</b> Hochfeste Verbindung, optisch ansprechend	<b>Advantages</b> High-strength connection, appealing design

2

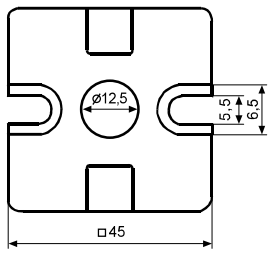

102 007 001		T-Verbinder	T Connector	
		<b>Stückzahl/Box</b>	<b>Quantity/box</b>	100
		<b>Gewicht/Stk.</b>	<b>Weight/pc</b>	55g
		<b>Gewicht/Box</b>	<b>Weight/box</b>	5,5kg
		<b>Höhe</b>	<b>Height</b>	13mm
		<b>Max. Belastung</b>	<b>max. load</b>	9000N
		<b>Biegemoment</b>	<b>Bending moment</b>	200Nm
		<b>Zubehör nicht inkl.:</b> 1 x Zentralschraube 2 x Hammermutter 2 x Schrauben	<b>Accessories not incl.:</b> 1 x Central Bolt M12x30 2 x T-Nut Slot 10 M6 2 x Screws M6x16	<b>102 006 002</b> <b>102 010 009</b> <b>102 009 001</b>

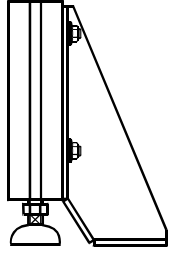

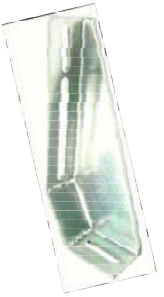
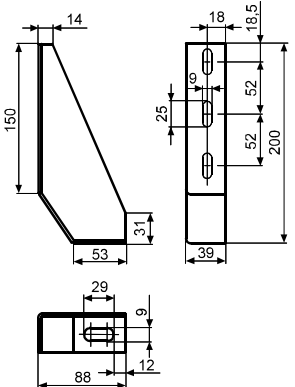
Fundamentwinkel  
Floor Bracket

		Allgemein	General
		<b>Material</b> Stahl verzinkt 4 mm, für Schrauben Ø 8 mm	<b>Material</b> Zinc plated steel 4 mm thickness for screws Ø 8 mm
		<b>Anwendung</b> Feste Verankerung von Aluminiumprofilstrukturen auf dem Fußboden	<b>Application</b> To securely fix aluminium profiles to the floor to prevent any movement of the structure

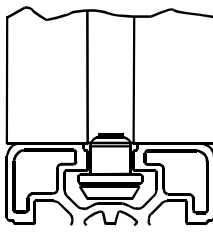
102 003 001		Fundamentwinkel	Floor Bracket	
		<b>Stückzahl/Box</b>	<b>Quantity/box</b>	10
		<b>Gewicht/Stk.</b>	<b>Weight/pc</b>	550g
		<b>Gewicht/Box</b>	<b>Weight/box</b>	5,50kg
		<b>Zubehör nicht inkl.:</b> 2 x Hammerschraube 2 x Flanschmutter	<b>Accessories not incl.:</b> 2 x T-Bolt M8x25 2 x Flange nut	<b>102 010 001</b> <b>102 010 003</b>

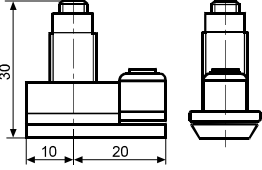

## Multiverbinder Multi Connector



Allgemein	General		
<b>Material</b> Stahl, verzinkt	<b>Material</b> Steel, zinc plated		
<b>Anwendung</b> Zur rechtwinkligen Verbindung von Profilen 40x40 oder 45x45 mit anderen Profilen (Nut 10)	<b>Application</b> To connect a profile 40x40 or 45x45 to any profile with slot 10 rectangularly		
<b>Vorteile</b> Kein Bohren nötig, verstellbar, nicht sichtbar	<b>Advantages</b> No tapping, adjustable, not visible		

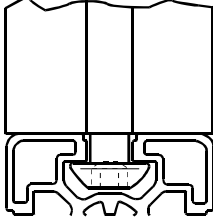

Multiverbinder	Multi Connector		102 005 001
Stückzahl/Box	Quantity/box	10	
Gewicht/Stk.	Weight/pc	39g	
Gewicht/Box	Weight/box	0,39kg	
Zubehör inkl.:	Accessories incl.:		
1 x Schneidhülse	1 x Cutting bush		
1 x Schraube M8	1 x M8 screw		
Werkzeug für Schneidhülse auf Anfrage	Tool for the cutting bush on request		
			

2

## Zentralschraube Central Bolt

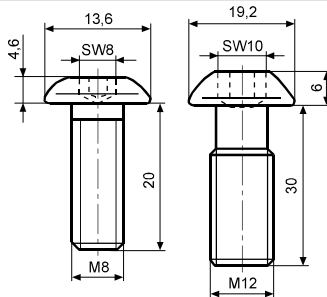
Allgemein	General		
<b>Material</b> Stahl, verzinkt, 8,8	<b>Material</b> Steel, zinc plated, 8,8		
<b>Anwendung</b> Zur rechtwinkligen Verbindung von Profilen	<b>Application</b> To connect profiles rectangularly		
<b>Vorteile</b> Nicht sichtbar, preiswert	<b>Advantages</b> Not visible, low cost		





Zentralschraube	Central Bolt		102 006 ...
<b>M8x20</b>	<b>M8x20</b>	200	M8: 001
Stückzahl/Box	Quantity/box	10g	M12: 002
Gewicht/Stk.	Weight/pc	2,0kg	
Gewicht/Box	Weight/box		
<b>M12x30</b>	<b>M12x30</b>	100	
Stückzahl/Box	Quantity/box	29g	
Gewicht/Stk.	Weight/pc	2,9kg	
Gewicht/Box	Weight/box		
			
			

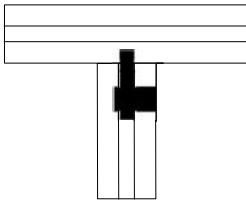

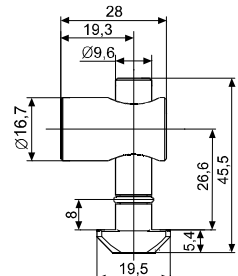

Gewindeformende Zentralschraube Torx	Thread Forming Central Bolt Torx		102 006 ...
<b>S8x25</b>	<b>S8x25</b>	100	S8: 004
Stückzahl/Box	Quantity/box	11g	S12: 003
Gewicht/Stk.	Weight/pc	1,1kg	
Gewicht/Box	Weight/box		
<b>S12x30</b>	<b>S12x30</b>	100	
Stückzahl/Box	Quantity/box	25g	
Gewicht/Stk.	Weight/pc	2,5kg	
Gewicht/Box	Weight/box		
			
			⊕ T40 ⊕ T50

## Schnellspanverbinder Quick Connectors

		Allgemein	General
		<b>Material</b> Stahl, verzinkt	<b>Material</b> Steel, zinc plated
		<b>Anwendung</b> Zur rechtwinkligen Verbindung von zwei Profilen	<b>Application</b> To make a solid, rectangular connection of two profiles
		<b>Vorteile</b> Hohe Zugfestigkeit, problemloses Einsetzen von Flächenelementen	<b>Advantages:</b> High tensile strength, easy to insert panels

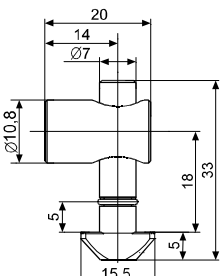
2







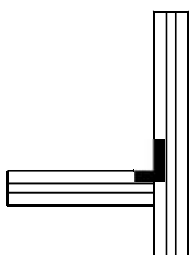



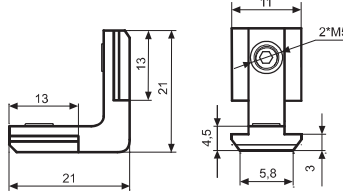



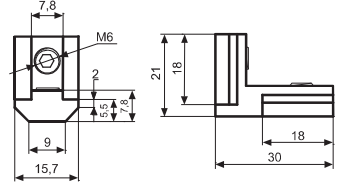



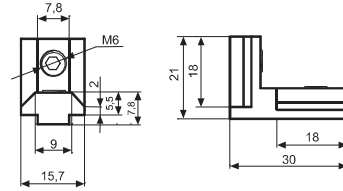

102 023 ...		25 Nm	Schnellspanverbinder	Quick Connector	
0° : 005	90° : 006		Stückzahl/Box Gewicht/Stk. Gewicht/Box	Quantity/box Weight/pc Weight/box	100 55g 5,5kg
			Bohrung (Ø) Abstand zum Profilende	Drilling (Ø) Distance to the end of profile	17mm 22,5mm
			Tiefe 40x40 Tiefe 45x45	Depth 40x40 Depth 45x45	31mm 34mm
			<b>4000 N</b>		<b>140 Nm</b>

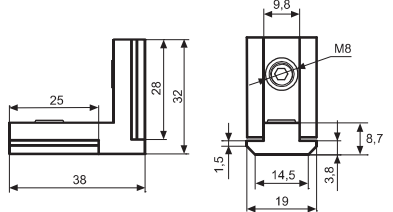
102 023 ...		12 Nm	Schnellspanverbinder	Quick Connector	
0° : 001	90° : 002		Stückzahl/Box Gewicht/Stk. Gewicht/Box	Quantity/box Weight/pc Weight/box	100 20g 2,0kg
			Bohrung (Ø) Abstand zum Profilende	Drilling (Ø) Distance to the end of profile	11mm 18mm
			Tiefe 30x30	Depth 30x30	22mm
			<b>500 N</b>		<b>40 Nm</b>

## Innenwinkel Inner Brackets

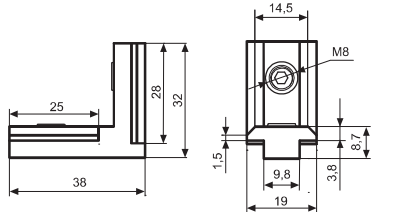
		Allgemein	General
		<b>Material</b> Zink-Druckguss; Oberfläche: vernickelt	<b>Material</b> Die-cast zinc; Surface: Nickel plated
		<b>Anwendung</b> Rahmen, leichte Regale, Vitrinen	<b>Application</b> Frames, light shelves, displays
		<b>Vorteile</b> Keine Bearbeitung oder Bohrung nötig, einfache Montage	<b>Advantage</b> No machining or drilling necessary, easy mounting

## Innenwinkel Inner Brackets

<b>Innenwinkel Nut 6</b>		<b>Inner bracket slot 6</b>		<b>102 026 005</b>	
Stückzahl/Box	Quantity/box	100			
Gewicht/Stk.	Weight/pc	3g			
Gewicht/Box	Weight/box	0,3kg			
<b>Schrauben inklusive</b>		<b>Including screws</b>			
 <b>600 N</b>	 <b>10 Nm</b>				
<b>Innenwinkel Nut 8, A</b>		<b>Inner bracket slot 8, A</b>		<b>12 Nm</b>	<b>102 026 001</b>
Stückzahl/Box	Quantity/box	100			
Gewicht/Stk.	Weight/pc	24g			
Gewicht/Box	Weight/box	2,4kg			
<b>Schrauben inklusive</b>		<b>Including screws</b>			
 <b>2500 N</b>	 <b>50 Nm</b>				
<b>Innenwinkel Nut 8, B</b>		<b>Inner bracket slot 8, B</b>		<b>12 Nm</b>	<b>102 026 002</b>
Stückzahl/Box	Quantity/box	100			
Gewicht/Stk.	Weight/pc	24g			
Gewicht/Box	Weight/box	2,4kg			
<b>Schrauben inklusive</b>		<b>Including screws</b>			
 <b>2200 N</b>	 <b>50 Nm</b>				
<b>Innenwinkel Nut 10, A</b>		<b>Inner bracket slot 10, A</b>		<b>15 Nm</b>	<b>102 026 003</b>
Stückzahl/Box	Quantity/box	100			
Gewicht/Stk.	Weight/pc	44g			
Gewicht/Box	Weight/box	4,40kg			
<b>Schrauben inklusive</b>		<b>Including screws</b>			
 <b>3000 N</b>	 <b>100 Nm</b>				
<b>Innenwinkel Nut 10, B</b>		<b>Inner bracket slot 10, B</b>		<b>15 Nm</b>	<b>102 026 004</b>
Stückzahl/Box	Quantity/box	100			
Gewicht/Stk.	Weight/pc	44g			
Gewicht/Box	Weight/box	4,40kg			
<b>Schrauben inklusive</b>		<b>Including screws</b>			
 <b>2800 N</b>	 <b>100 Nm</b>				

**Inline-Verbinder**  
**Inline Connectors**

2

	Allgemein	General
--	-----------	---------



**Material**  
Stahl, verzinkt

**Material**  
Zinc plated steel

**Anwendung**  
Zur rechtwinkligen stabilen Verbindung von zwei Aluminium-Profilen

**Application**  
To Connect two aluminum profiles

**Vorteile**  
Schnell und solide; Montage ohne Profilbearbeitung

**Advantage**  
Fast and solid; assembly without machining

102 008 004

**Inline Verbinder Set**

**Inline Connector Set**

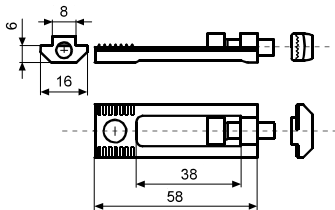

Stückzahl/Box  
Gewicht/Stk.  
Gewicht/Box  
**Schraube und Hammermutter**

Quantity/box  
Weight/pc  
Weight/box  
**Including screw and T Nut**

102 008 002

**Inline Verbinder Set**

**Inline Connector Set**

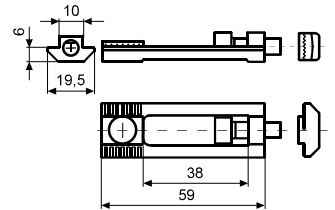

Stückzahl/Box  
Gewicht/Stk.  
Gewicht/Box  
**Schraube und Hammermutter**

Quantity/box  
Weight/pc  
Weight/box  
**Including screw and T Nut**

## Bolzenverbinder Bolt Connectors

Allgemein	General
-----------	---------

### Material

Grundkörper: Stahl, verzinkt  
Schrauben: Stahl, verzinkt  
Hammermüttern: Stahl, verzinkt  
Fixierbolzen: Kunststoff PA, glasfaserverstärkt  
Schraubenabdeckungen: Kunststoff PA, glasfaserverstärkt

### Anwendung

Zur rechtwinkligen stabilen Verbindung von zwei Aluminiumprofilen

### Vorteile

Für hohe Belastungen - und Torsion geeignet

### Material

Base element: Zinc plated steel  
Screws: Zinc plated steel  
Hammer nuts: Zinc plated steel  
Fixing bolts: Nylon PA, glass fibre reinforced  
Screw covers: Nylon PA, glass fibre reinforced

### Application

To connect two aluminum profiles rectangularly

### Advantage

suitable for heavy loads and torsional stress



2

Bolzenverbinder Set	Bolt Connector Set	 	102 008 ...
---------------------	--------------------	---	-------------

Stückzahl/Box

Gewicht/Set

Gewicht/Box

**Inklusive Schrauben und Hammermüttern**

Quantity/box

Weight/Set

Weight/box

**Including screws and T Nuts**

10

See table

See table

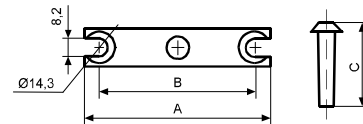
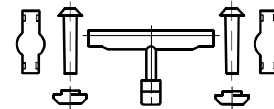

Profiltyp Profile type	Bestellnr. Order code 102 008 ...			Bohrungs Ø Bore Ø	Schraube Screw		Gewicht / Set Weight / Set	Gewicht / Box Weight / Box	A	B	C
30x30	005	2500N	60Nm	8,2mm	M5	6Nm	26g	0,26kg	28mm	18mm	25mm
40x40	006	4000N	180Nm	17mm	M8	25Nm	74g	0,74kg	37mm	23mm	35mm
45x45	007	4000N	190Nm	17mm	M8	25Nm	78g	0,78kg	42mm	28mm	35mm
60x60	008	4000N	200Nm	17mm	M8	25Nm	83g	0,83kg	57mm	43mm	35mm
80x80	009	5000N	800Nm	17mm	M8	25Nm	121g	1,21kg	77mm	63mm	35mm
90x90	010	5000N	800Nm	17mm	M8	25Nm	133g	1,33kg	87mm	73mm	35mm

1) Jeweils 2 Bolzenverbinder je Verbindung  
1) 2 Bolt Connectors for each connection

## 45° Verbinder 45° Connectors

	Allgemein	General
--	-----------	---------



**Material**

Aluminiumdruckguss  
blanke Oberfläche  
Abdeckkappe PA, schwarz

**Anwendung**

Zur 45° Verbindung  
von Profilen

**Vorteile**

Zur Versteifung von  
Strukturen

**Material**

Die cast aluminium  
plain surface  
cover cap PA, black

**Application**

To connect profiles  
under 45°

**Advantages**

To make structures more rigid

2

102 029 001

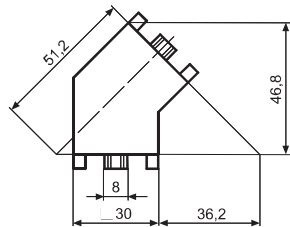

**45° Verbinder 30**

Stückzahl/Box  
Gewicht/Stk.  
Gewicht/Box

1 x Abdeckkappe inkl.

Zubehör nicht inkl.:  
2 x Schrauben M8  
Mutter(n)

**45° Connector 30**

Quantity/box  
Weight/pc  
Weight/box

1 x Cover cap incl.

Accessories not incl.:  
2 x Screw M8  
Nut(s)



102 029 002

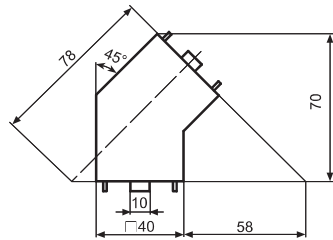

**45°Verbinder 40**

Stückzahl/Box  
Gewicht/Set  
Gewicht/Box

Zubehör inkl.:  
1 x Hammerschraube  
1 x Flanschnutter  
1 x Abdeckkappe  
2 x Schraube

**45° Connector 40**

Quantity/box  
Weight/Set  
Weight/box

Accessories incl.:  
1 x T-Bolt M8x20  
1 x Flange nut  
1 x Cover cap  
2 x Bolt



**M8x20  
M8**

**S12x3**

102 029 003

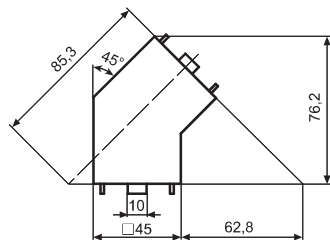

**45° Verbinder 45**

Stückzahl/Box  
Gewicht/Stk.  
Gewicht/Box

1 x Abdeckkappe inkl.

Zubehör nicht inkl.:  
2 x Schrauben M12  
Mutter(n)

**45° Connector 45**

Quantity/box  
Weight/pc  
Weight/box

1 x Cover cap incl.

Accessories not incl.:  
2 x Screw M12  
Nut(s)



**0,775kg**

## Profilverbinder Profile Connectors

Allgemein	General
-----------	---------

**Material**

Stahl, verzinkt

**Anwendung**

Zur Längsverbinding von Profilen

**Material**

Steel, zinc plated

**Application**

To make connections for profiles end to end

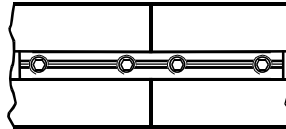

Profilverbinder	Profile connector		102 008 003
-----------------	-------------------	---	-------------

Stückzahl/Box

Quantity/box

50

Gewicht/Stk.

Weight/pc

100g

Gewicht/Box

Weight/box

5,0kg

Im Lieferumfang enthalten:

Included in delivery:

4x Gewindestift M8x10

4x headless screw M8x10

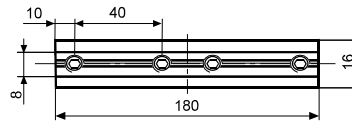

2

Profilverbinder	Profile connector		102 008 001
-----------------	-------------------	---	-------------

Stückzahl/Box

Quantity/box

25

Gewicht/Stk.

Weight/pc

190g

Gewicht/Box

Weight/box

4,75kg

Im Lieferumfang enthalten:

Included in delivery:

4x Gewindestift M8x10

4x headless screw M8x10

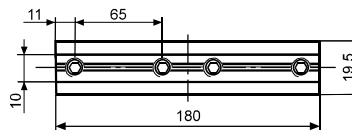



**Schutzzaunwinkel Set**  
**Fence Bracket Set**

2

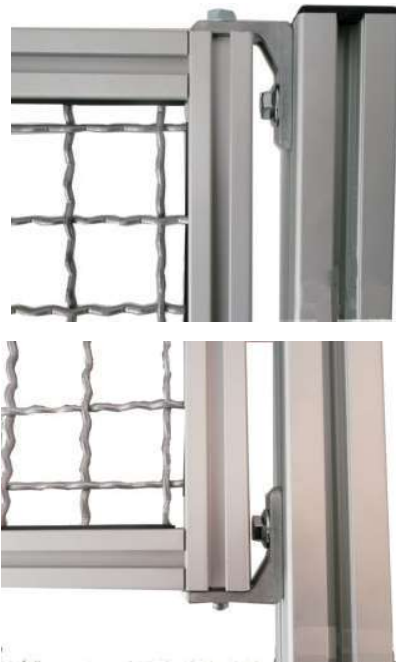

Allgemein	General
<p><b>Material</b> Zinkdruckguss</p> <p><b>Anwendung</b> Zur Befestigung von Schutzzaunfeld zwischen 2 Profilen</p> <p><b>Vorteile</b> Langlöcher Ein-Mann-Montage dank Einhängung von unten</p>	<p><b>Material</b> Die cast zinc</p> <p><b>Application</b> To mount a protection fence frame between to profiles</p> <p><b>Advantages</b> Long holes one-man-assembly, due to pins at bottom</p>

102 040 001	Schutzzaunwinkel Set	Fence Bracket Set	
-------------	----------------------	-------------------	--



Stückzahl/Box	Quantity/box	1 (4pcs)
Gewicht/Stk.	Weight/pc	106g
Gewicht/Box	Weight/box	0,11kg
<b>Im Lieferumfang enthalten:</b>	<b>Included in delivery:</b>	
4 Einhängewinkel	4 suspension brackets	
4 Flanschnuttern M8	4 flange nuts M8	
4 Hammerschrauben M8x20	4 hammer head screws M8x20	
2 Sicherungsschrauben M8x16	2 locking screws M8x16	
2 Zapfen Ø8,6 mit Rändel für Kernbohrung	2 knurled pins Ø8,6, for core bore	

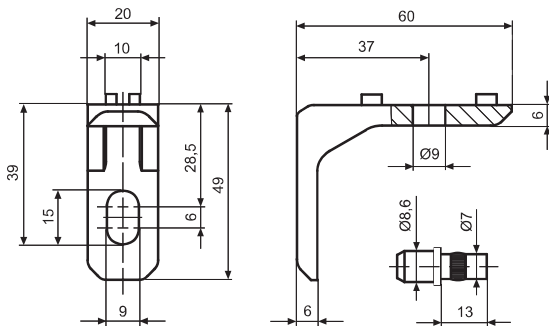

## Schutzzaunfuß Fence Mount Base

Allgemein	General
-----------	---------

**Material**  
Aluminiumdruckguss

**Material**  
Die cast Aluminium

**Anwendung**  
Zur Montage von  
Profilpfosten am  
Boden

**Application**  
To mount  
profile pillars  
to the floor

**Vorteile**  
Neigungsausgleich  
optisch ansprechend

**Advantages**  
Aligning feature  
appealing design



2

Schutzzaunfuß 40/45	Fence Mount Base 40/45		102 003 ...
---------------------	------------------------	---	-------------

Stückzahl/Box	Quantity/box	1	40x40: 003    45x45: 004
Zubehör nicht inkl.	Accessories not incl.		

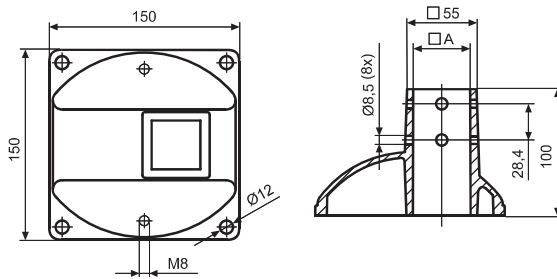

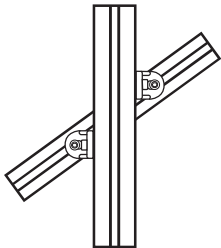

Profiltyp Profile type	Bestellnr. Order Code 102 003 ...	A	Gewicht / St Weight / Pc	Gewicht / Box Weight / Box
40x40	003	40	940g	0,94kg
45x45	004	45	820g	0,82kg

## Drehwinkel Swivel Brackets

		Allgemein	General
		<b>Material</b> Aluminiumdruckguss <b>Anwendung</b> Zur Verbindung von Profilen in verstellbarem Winkel <b>Vorteile</b> Keine Profilbearbeitung nötig	<b>Material</b> Aluminium die cast <b>Application</b> To connect profiles at an adjustable <b>Advantages</b> No machining on profiles required

2

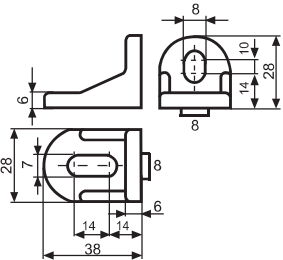
102 004 001	Drehwinkel 28x38R	Swivel Bracket 28x38R	
		Stückzahl/Box Gewicht/Stk. Gewicht/Box	Quantity/box Weight/pc Weight/box 10 16g 0,16kg

102 004 002	Drehwinkel 40x43R	Swivelbracket 40x43R	 
		Stückzahl/Box Gewicht/Stk. Gewicht/Box	Quantity/box Weight/pc Weight/box 10 45g 0,45kg

## Gelenke Joints

Allgemein	General
-----------	---------

**Material**

Gelenk: Zinkdruckguss  
Klemmhebel: Kunststoff PA, glasfaserverstärkt

**Anwendung**

zur Verbindung von zwei Profilen oder Flächenelementen in beliebigen Winkeln fixierbar. Mit Führungsnasen für Nut 8 oder Nut 10.

**Vorteile**

Mittels der Schrauben und des Klemmhebels kann der Reibungswiderstand des Gelenkes stufenlos reguliert, bzw. das Gelenk in einer definierten Position fixiert werden

**Material**

Joint: Die-cast zinc  
Locking lever: Nylon PA, glass filled reinforced

**Application**

To make a pivoting connection between 2 profiles or panels which can be fixed at any angle; fixed locating pins for slot 8 or 10 optional

**Advantages**

By tightening or loosening the screw and the locking lever you can seamlessly regulate the functionality of the joint or you can fix it in one position



2

Gelenk 30 mit Klemmhebel	Pivot Joint 30 with Lever		102 028 705
--------------------------	---------------------------	---	-------------

Stückzahl/Box  
Gewicht/Stk.  
Gewicht/Box

Quantity/box  
Weight/pc  
Weight/box

**Zudem erhältlich:**  
Gelenk 30 ohne Klemmhebel

**Also available:**  
Pivot Joint 30 without lever  
102 028 709

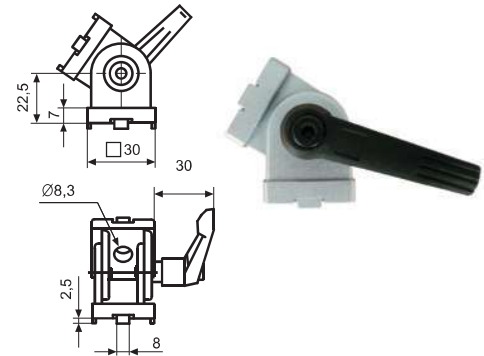

Gelenk 40/45 mit Klemmhebel	Pivot Joint 40/45 with Lever		102 028 ...
-----------------------------	------------------------------	---	-------------

Stückzahl/Box  
Gewicht/Stk.  
Gewicht/Box

Quantity/box  
Weight/pc  
Weight/box

**Zudem erhältlich:**  
Gelenk 40 ohne Klemmhebel

**Also available:**  
Pivot Joint 40 without lever  
102 028 707

**Gelenk 45 ohne Klemmhebel**

**Pivot Joint 45 without lever**  
102 028 704

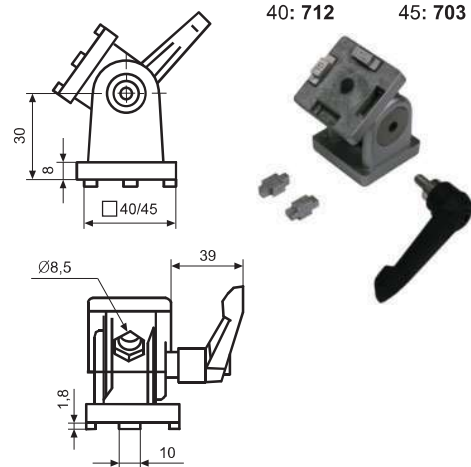

## Schwenkwinkel Pivoting Bracket

2

	Allgemein	General
--	-----------	---------



**Material**

Stahl, verzinkt

**Anwendung**

Einstellbare Winkelverbindung, arretierbar

**Material**

Steel, zinc plated

**Application**

Adjustable angle connector, lockable

102 004 003

**Schwenkwinkel**

**Pivoting Bracket**



Stückzahl/Box

Quantity/box

10

Gewicht/Stk.

Weight/pc

220g

Gewicht/Box

Weight/box

2,2kg

Zubehör nicht inkl.

Accessories not incl.

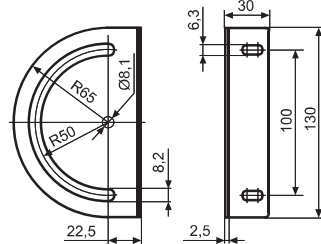

102 004 702

**Klemmhebel**

**Clamp Lever**



**Material**

Kunststoff, glasfaserverstärkt  
Stahl, verzinkt

**Material**

Plastic, glass fibre reinforced steel, zinc plated

Gewinde

Thread

M8x15mm

Stückzahl/Box

Quantity/box

10

Gewicht/Stk.

Weight/pc

g

Gewicht/Box

Weight/box

kg

**Hinweis:**

Für Nut 8 bitte U-Scheiben verwenden, wegen Gewindelänge

**Hint:**

for Slot 8 kindly use washers, due to thread length

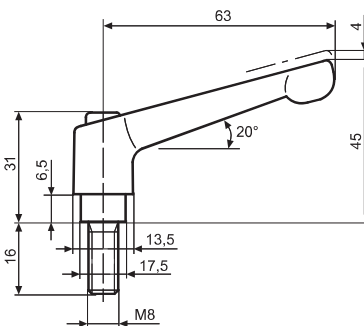

**Stellfüße, Lenkrollen**  
**Feet, Castors**



**Seite/Page 36-37**

**Lenkrollen ESD**  
**Castors ESD**



**Seite/Page 38**

**Transport- und Fußplatten**  
**Transport- and Base Plates**



**Seite/Page 39**