

Spare parts for CH cylinders

1 EXPLODED VIEW OF THE CYLINDER

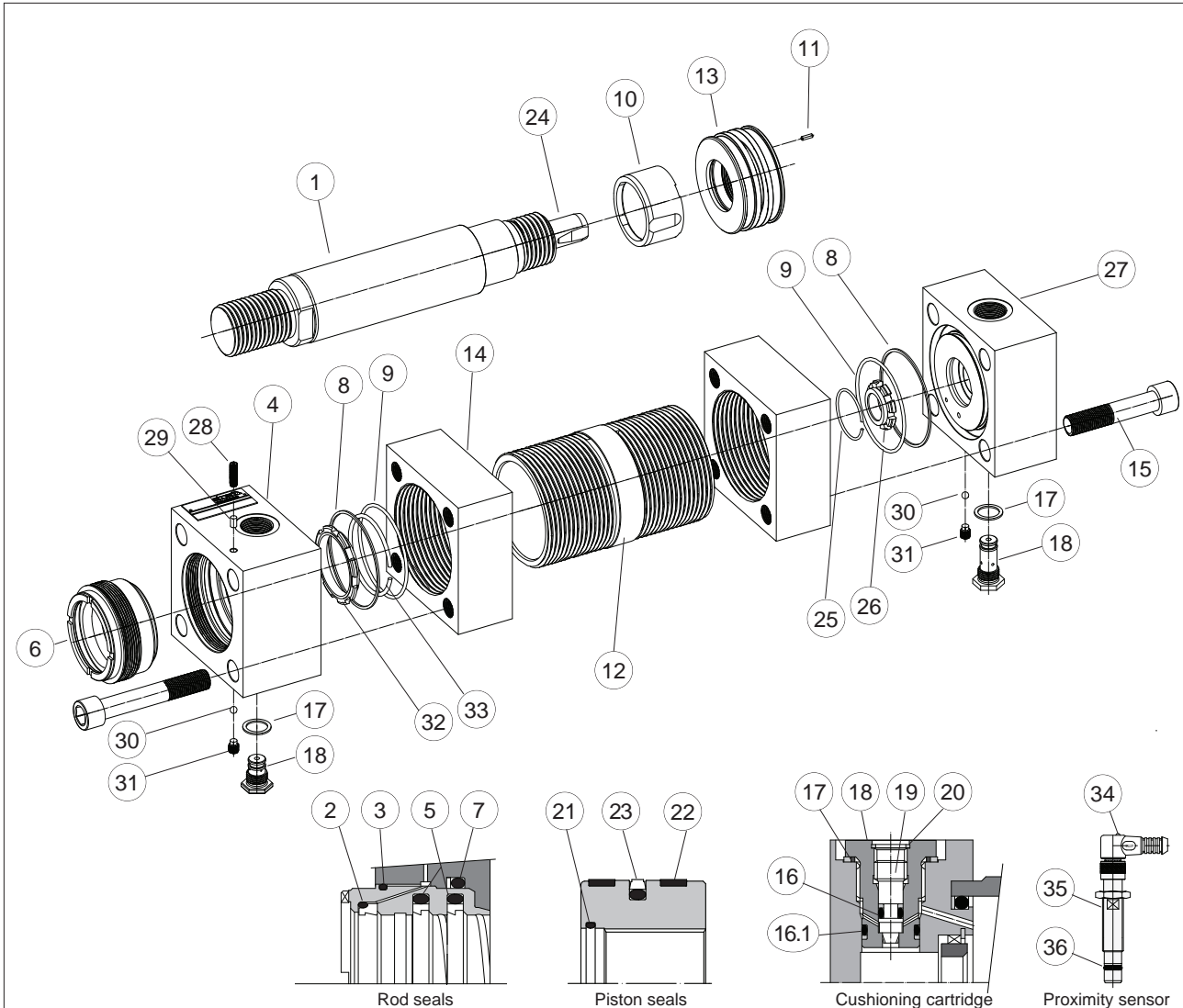

POS	DESCRIPTION	POS	DESCRIPTION
1	Rod	19	Cushioning adjustment screw
2	Wiper	20	Seeger
3	O-ring + Antiextrusion ring - rod bearing	21	O-ring - piston
4	Front head	22	Piston wear rings
5	Rod seal	23	Piston seal
6	Rod bearing - bronze	24	Rear cushioning piston
7	O-Ring + Antiextrusion ring - Rod bearing	25	Toroidal ring - rear
8	Antiextrusion ring - cylinder housing	26	Cushioning sleeve - rear
9	O-ring - cylinder housing	27	Rear head
10	Front cushioning piston	28	Grub screw - rod bearing locking
11	Locking pin - piston/rod	29	Teflon pad - rod bearing locking
12	Cylinder housing	30	Steel sphere - air bleed
13	Piston	31	Grub screw - air bleed
14	Counterflange	32	Cushioning sleeve - front
15	Screw	33	Toroidal ring - front
16	O-ring + Antiextrusion ring - cushioning screw	34	Connector for proximity sensor
16.1	O-ring + Antiextrusion ring - cushioning cartridge	35	Proximity sensor
17	Seal	36	O-ring - proximity sensor
18	Cushioning adjustment cartridge		

2 ROD AND PISTON SEALS

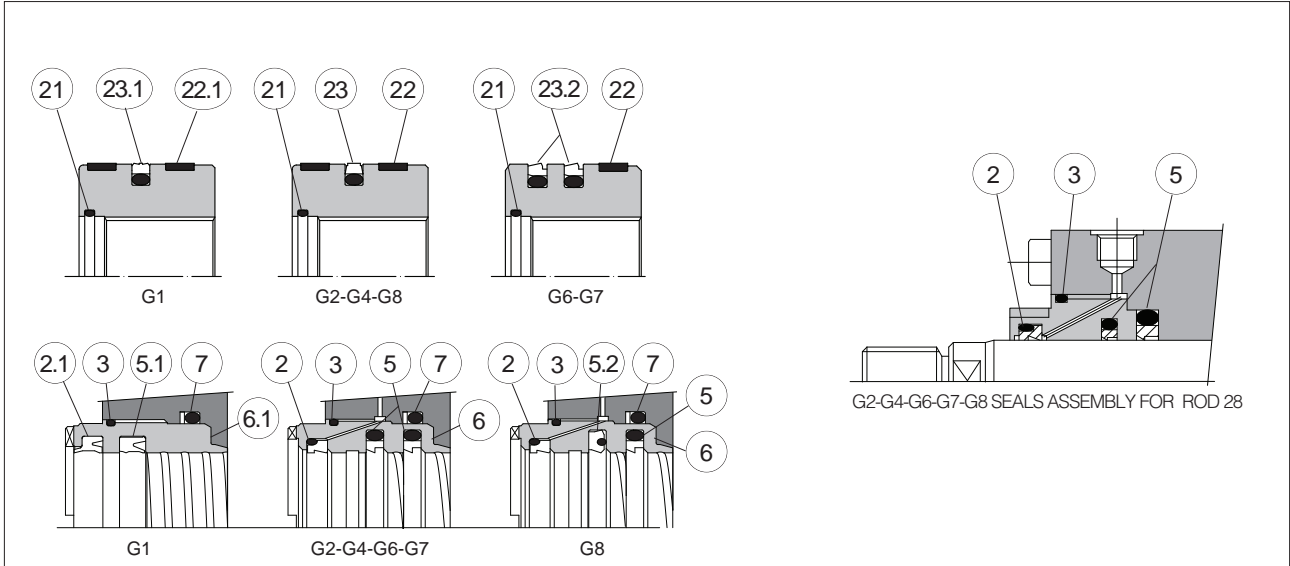

3 CUSHIONING CARTRIDGES

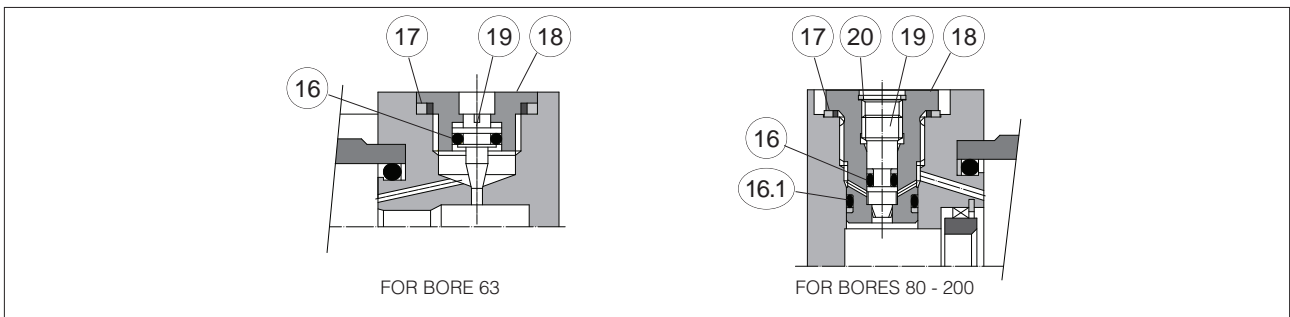

4 ASSEMBLING TOOLS

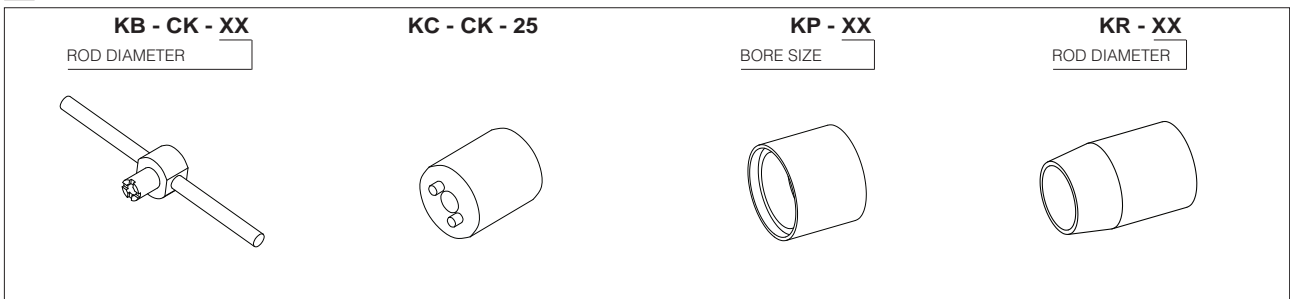

ASSEMBLING OPERATION	CYLINDER SIZE	TOOL	TOOL DIMENSION	TORQUE [Nm]
Rod bearing (pos. 6) assembling	Bores 63 - 200	KB - CK - XX	According to the rod diameter	see table SP-B600, section 1
Cushioning adjustment cartridge (pos.18) assembling	Bore 63	KC - CK - 25	-	6,9
	Bores 80 - 200	Hexagonal wrench	22	19,6
Screws (pos. 15) for heads assembling	Bores 63 - 200	Hexagonal wrench	see table B140, section 4	see table B140, section 4
Grub screw (pos. 28) for rod bearing locking	Bore 80	Allen key	3	5
	Bores 100 - 160		4	6
	Bore 200		6	7
Grub screw (pos. 31) for air bleed screwing	Bores 50 - 200	Allen key	4	6
Calibration of piston seal	Bores 25 - 200	KP - XX	According to the bore size	-
Calibration of rod seals	Bores 25 - 200	KR - XX	According to the rod diameter	-

5 SPARE PARTS CODES

5.1 Seals

ORDER CODE	POS	DESCRIPTION	G1	G8	G2-G4	G6-G7
<p>G1 - CK - 50 / 22 / 22 - 26</p> <p>G1 - v < 0,5 m/s G2 - v > 1 m/s up to 120°C G4 - v > 1 m/s G6 - single effect pushing G7 - single effect pulling G8 - v < 0,5 m/s</p> <p>BORE SIZE</p> <p>ROD DIAMETER</p> <p>SECOND ROD DIAMETER (double rod)</p> <p>SERIES NUMBER (indicate only for series <30)</p>	2	Wiper - PTFE		•	•	•
	2.1	Wiper - polyurethane (ISO 6195)	•			
	3	O-ring + Antiextrusion ring - rod bearing	•	•	•	•
	5	Rod seal - PTFE (ISO 7425)		•	• [2]	• [2]
	5.1	Rod seal - polyurethane (ISO 5597)	•			
	5.2	Rod seal - polyurethane (ISO 7425)		•		
	7	O-Ring + Antiextrusion ring - Rod bearing	•	•	•	•
	8	Antiextrusion ring - cylinder housing	• [2]	• [2]	• [2]	• [2]
	9	O-ring - cylinder housing	• [2]	• [2]	• [2]	• [2]
	11	Locking pin - piston/rod	•	•	•	•
	16	O-ring + Antiextrusion ring - cushioning screw	• [2]	• [2]	• [2]	• [2]
	16.1	O-ring + Antiextrusion ring - cushioning cartridge	• [2]	• [2]	• [2]	• [2]
	17	Seal	• [2]	• [2]	• [2]	• [2]
	21	O-ring - piston	•	•	•	•
	22	Piston wear rings - PTFE		• [2]	• [2]	•
	22.1	Piston wear rings - phenolic resin	• [2]			
	23	Piston seal - PTFE (ISO 7425)		•	•	
	23.1	Piston seal - polyurethane (ISO 7425)	•			
	23.2	Piston seal - PTFE (ISO 7425)				• [2]

5.2 Rod bearings

ORDER CODE	POS	DESCRIPTION	G1	G8	G2-G4	G6-G7
<p>B1 - CK - 50 / 22 - HJ - 26</p> <p>B1 - G1 B2 - G2 B4 - G4, G6, G7 B8 - G8</p> <p>BORE SIZE</p> <p>ROD DIAMETER</p> <p>DRAINING (indicate only for option L)</p> <p>SERIES NUMBER (indicate only for series <30)</p>	2	Wiper - PTFE		•	•	•
	2.1	Wiper - polyurethane (ISO 6195)	•			
	3	O-ring + Antiextrusion ring - rod bearing	•	•	•	•
	5	Rod seal - PTFE (ISO 7425)		•	• [2]	• [2]
	5.1	Rod seal - polyurethane (ISO 5597)	•			
	5.2	Rod seal - polyurethane (ISO 7425)		•		
	6	Rod bearing		•	•	•
	6.1	Rod bearing	•			

5.3 Piston rod

ORDER CODE	POS	DESCRIPTION	G1	G8	G2-G4	G6-G7
<p>U - CK - 63 / 28 / 28 x 500...</p> <p>COMPLETE CYLINDER CODE + SERIES NUMBER</p>	1	Rod	•	•	•	•
	10	Front cushioning piston (if selected)	•	•	•	•
	11	Locking pin - piston/rod	•	•	•	•
	13	Piston	•	•	•	•
	21	O-ring - piston	•	•	•	•
	22	Piston wear rings - PTFE		• [2]	• [2]	•
	22.1	Piston wear rings - phenolic resin	• [2]			
	23	Piston seal - PTFE (ISO 7425)		•	•	
	23.1	Piston seal - polyurethane (ISO 7425)	•			
	23.2	Piston seal - PTFE (ISO 7425)				• [2]

5.4 Cushioning

ORDER CODE	POS	DESCRIPTION	Front F2 - F5	Rear F1
<p>F1 - CK - 50 / 22 - N - 26</p> <p>F1 - rear cushioning F2 - front cushioning fast F5 - front cushioning slow</p> <p>BORE SIZE</p> <p>ROD DIAMETER</p> <p>MOUNTING STYLE (indicate only for N,P cushioning E2,E4,Z2,Z4)</p> <p>SERIES NUMBER (indicate only for series <30)</p>	10	Front cushioning piston	•	
	16	O-ring + Antiextrusion ring - cushioning screw	•	•
	16.1	O-ring + Antiextrusion ring - cushioning cartridge	•	•
	17	Seal	•	•
	18	Cushioning adjustment cartridge	•	•
	19	Cushioning adjustment screw	•	•
	20	Seeger	•	•
	25	Toroidal ring - rear		•
	26	Cushioning sleeve - rear		•
	32	Cushioning sleeve - front	•	
	33	Toroidal ring - front	•	

5.5 Proximity sensors

ORDER CODE	POS	DESCRIPTION	BORES							
			40	50	63	80	100	125	160	200
CX320520731	35	Proximity sensor			•	•	•	•		
CX320520715	35	Proximity sensor	•	•	•	•	•			
CX320520719	35	Proximity sensor				•	•	•	•	•
VA110000003	34	Connector for proximity sensor	•	•	•	•	•	•	•	•