

Attachments for hydraulic cylinders

to ISO 6982, ISO 8132 and ISO 8133

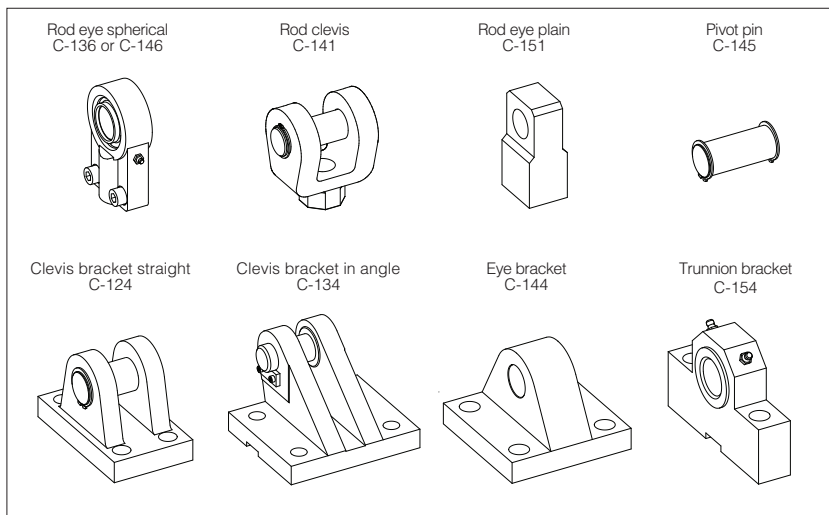

The table at side shows the Atos range of standard rod attachments and brackets: they are available for each cylinder bore. See section 2 for possible combinations. Stainless steel attachments are available on request.

1 MODEL CODE

C	-	141	12	-	V
Standard attachment			Painting see sect. 5		

Rod attachments:

- 136= Rod eye spherical
- 146= Rod eye spherical
- 141= Rod clevis
- 151= Rod eye plain
- 145= Pivot pin

Brackets:

- 124 = Clevis bracket straight
- 134 = Clevis bracket in angle
- 144 = Eye bracket
- 154 = Trunnion bracket









Bore size/rod diameter [mm]

SWC Cylinders Designer

Software for assisted selection of Atos cylinders & servocylinders codes, including cylinder's sizing, full technical information, 2D & 3D drawings in several CAD formats.

Available for download at www.atos.com

2 POSSIBLE COMBINATIONS

Ø Rod	Rod attachments codes					Ø Bore	Brackets codes			
	 (a)									
12 18 opt.H(b)	NA	C-14612	C-14112	C-15112	C-14512	25	NA	C-13425	C-14425	C-15425
14 22 opt.H(b)	C-13616	C-14614	C-14114	C-15114	C-14514	32	NA	C-13432	C-14432	C-15432
18 28 opt.H(b)	C-13618	C-14618	C-14118	C-15118	C-14518	40	C-12422 (c)	C-13440	C-14440	C-15440
22 36 opt.H(b)	C-13622	C-14622	C-14122	C-15122	C-14522	50	C-12428 (c) C-12436 (d)	C-13450	C-14450	C-15450
28 45 opt.H(b)	C-13628	C-14628	C-14128	C-15128	C-14528	63	C-12436 (c) C-12445 (d)	C-13463	C-14463	C-15463
36 56 opt.H(b)	C-13636	C-14636	C-14136	C-15136	C-14536	80	C-12445 (c) C-12456 (d)	C-13480	C-14480	C-15480
45 70 opt.H(b)	C-13645	C-14645	C-14145	C-15145	C-14545	100	C-12456 (c) C-12470 (d)	C-134100	C-144100	C-154100
56 90 opt.H(b)	C-13656	C-14656	C-14156	C-15156	C-14556	125	C-12470 (c) C-12490 (d)	C-134125	C-144125	C-154125
70 110 opt.H(b)	C-13670	C-14670	C-14170	C-15170	C-14570	160	C-12490 (c) C-124100 (d)	C-134160	C-144160	C-154160
90 140 opt.H(b)	C-13690	C-14690	C-14190	C-15190	C-14590	200	C-124100 (c)	C-134200	C-144200	C-154200

Notes:

(a) Option H : light male thread, for details see table B137 or B140

(b) C-136 is also available for rods 110, 140, 180 and 220. See section 3

(c) For S mounting styles in CN cylinder

(d) For S mounting styles in CC cylinder

3 DIMENSIONS [mm]

Code	KK	AX	B	C	CB	CH	CN	EN	H	LF	NC	Mass	Max load [kN] (2)		Screws
		min	max	max	max	js13	H7	h12		min		[kg]	Dynamic	Static	torque
C-13616 (1)	M12x1,25	17	19	33	11	38	12	12	54	13	32	0,11	10,8	24,5	6 Nm
C-13618	M14x1,5	19	22	41	14	44	16	16	64	16,5	40	0,2	17,6	36,5	10 Nm
C-13622	M16x1,5	23	28	50	17,5	52	20	20	75	20,5	47	0,35	30	48	25 Nm
C-13628	M20x1,5	29	31	64	22	65	25	25	96	25,5	54	0,62	48	78	25 Nm
C-13636	M27x2	37	38	80	28	80	32	32	118	30	66	1,15	67	114	49 Nm
C-13645	M33x2	46	47	100	34	97	40	40	146	39	80	2,18	100	204	49 Nm
C-13656	M42x2	57	58	126	42	120	50	50	179	47	96	3,96	156	310	86 Nm
C-13670	M48x2	64	70	145	53,5	140	63	63	211	58	114	6,8	255	430	210 Nm
C-13690	M64x3	86	91	184	68	180	80	80	270	74	148	13	400	695	410 Nm
C-13690A (3)	M72x3	91	100	185	72	195	90	90	296	91	160	19,1	490	750	410 Nm
C-136110	M80x3	96	110	228	85,5	210	100	100	322	94	178	25	610	1.060	710 Nm
C-136110A (3)	M90x3	106	125	235	88	235	110	110	364	106	190	32	655	1.200	710 Nm
C-136140	M100x3	113	135	320	105	260	125	125	405	116	200	46	950	1.430	710 Nm
C-136180	M125x4	126	165	400	133	310	160	160	488	145	250	82,5	1.370	2.200	710 Nm
C-136220	M160x4	161	215	500	165	390	200	200	620	190	320	168	2.120	3.650	1500Nm

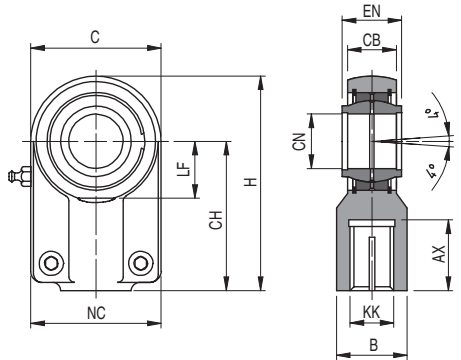

Notes:
 (1) This attachment does not include the greaser because it is selflubricated
 (2) Dynamic loads has to be considered when the cylinders work with oscillatory motions or push-pull loads in high frequencies
 (3) Without standards

Code	KK	AX	CH	CX	EF	EN	EU	LF	N	Mass	Max load [kN] (2)		Screws
		min	js13	max	max	EN	max	min	max	[kg]	Dynamic	Static	torque
C-14612 (1)	M10x1,25	15	42	12 ⁰ _{-0,008}	18	10 ⁰ _{-0,12}	8,5	16	19	0,12	10,8	17	10 Nm
C-14614 (1)	M12x1,25	17	48	16 ⁰ _{-0,008}	23	14 ⁰ _{-0,12}	11,5	20	22	0,22	21,1	28,5	10 Nm
C-14618 (1)	M14x1,5	19	58	20 ⁰ _{-0,01}	28	16 ⁰ _{-0,12}	13,5	25	28	0,43	30	42,5	25 Nm
C-14622	M16x1,5	23	68	25 ⁰ _{-0,01}	33	20 ⁰ _{-0,12}	18	30	31	0,67	48	67	25 Nm
C-14628	M20x1,5	29	85	30 ⁰ _{-0,01}	41	22 ⁰ _{-0,12}	20	35	37	1,25	62	108	49 Nm
C-14636	M27x2	37	105	40 ⁰ _{-0,012}	51	28 ⁰ _{-0,12}	24	45	47	2,16	100	156	49 Nm
C-14645	M33x2	46	130	50 ⁰ _{-0,012}	61	35 ⁰ _{-0,12}	31	58	57	3,9	156	245	86 Nm
C-14656	M42x2	57	150	60 ⁰ _{-0,015}	80	44 ⁰ _{-0,15}	39	68	69	7,15	245	380	210 Nm
C-14670	M48x2	64	185	80 ⁰ _{-0,015}	102,5	55 ⁰ _{-0,15}	48	92	91	15	400	585	410 Nm
C-14690	M64x3	86	240	100 ⁰ _{-0,02}	120	70 ⁰ _{-0,20}	57	116	110	27,3	610	865	710 Nm

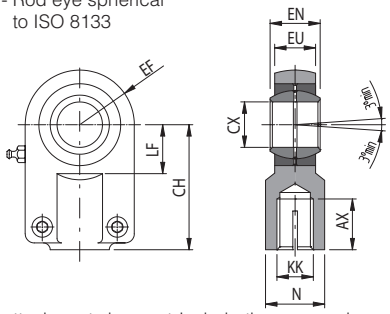

Notes:
 (1) This attachment does not include the greaser because it is selflubricated
 (2) Dynamic loads has to be considered when the cylinders work with oscillatory motions or push-pull loads in high frequencies

Code	KK	CE	CK	CL	CM	EK	EL	ER	LE	Mass	Max load
		JS13	H9	max	A13	f8	min	max	min	[kg]	static [kN]
C-14112 C-14512	M10x1,25	32	10	26	12	10	29	12	13	0,1	8
C-14112 C-14512	M12x1,25	36	12	34	16	12	37	17	19	0,18	12,5
C-14118 C-14518	M14x1,5	38	14	42	20	14	45	17	19	0,23	20
C-14122 C-14522	M16x1,5	54	20	62	30	20	66	29	32	0,9	32
C-14128 C-14528	M20x1,5	60	20	62	30	20	66	29	32	0,91	50
C-14136 C-14536	M27x2	75	28	83	40	28	87	34	39	1,92	80
C-14145 C-14545	M33x2	99	36	103	50	36	107	50	54	4,92	125
C-14156 C-14556	M42x2	113	45	123	60	45	129	53	57	6,53	200
C-14170 C-14570	M48x2	126	56	143	70	56	149	59	63	10,11	320
C-14190 C-14590	M64x3	168	70	163	80	70	169	78	83	19,2	500

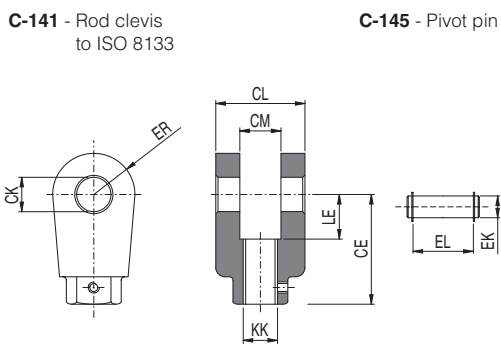

Note: Pivot pin C-145* is included in the supply

Code	KK	AW	B	CA	CB	CK	EM	ER	LE	Mass	Max load
		min		JS13	max	H9	h13	max	min	[kg]	static [kN]
C-15112	M10x1,25	14	18	32	18	10	12	12	13	0,08	8
C-15114	M12x1,25	16	22	36	22	12	16	17	19	0,15	12,5
C-15118	M14x1,5	18	25	38	20	14	20	17	19	0,22	20
C-15122	M16x1,5	22	35	54	30	20	30	29	32	0,5	32
C-15128	M20x1,5	28	40	60	30	20	30	29	32	1,1	50
C-15136	M27x2	36	50	75	40	28	40	34	39	1,5	80
C-15145	M33x2	45	70	99	50	36	50	50	54	2,5	125
C-15156	M42x2	56	100	113	65	45	60	53	57	4,2	200
C-15170	M48x2	63	116	126	90	56	70	59	63	11,8	320
C-15190	M64x3	85	160	168	110	70	80	78	83	17	500

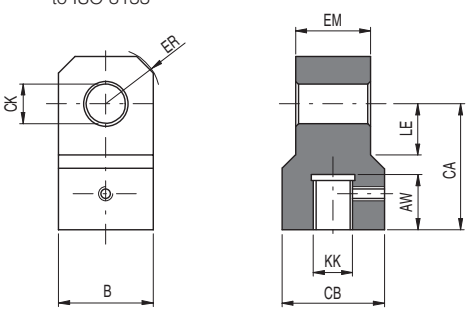

C-124 - Clevis bracket straight to ISO 8132	Code	CK	CL	CM	FL	HB	LE	MR	RC	TB	UD	UH	Mass	Max load
		H9	h16	A13	JS12	H13	min	max	JS14	JS14	max	max	[kg]	static [kN]
	C-12414	12	28	12	34	9	22	12	20	50	40	70	0,31	8
	C-12418	16	36	16	40	11	27	16	26	65	50	90	0,59	12,5
	C-12422	20	45	20	45	11	30	20	32	75	58	98	0,9	20
	C-12428	25	56	25	55	13,5	37	25	40	85	70	113	1,6	32
	C-12436	32	70	32	65	17,5	43	32	50	110	85	143	2,8	50
	C-12445	40	90	40	76	22	52	40	65	130	108	170	5	80
	C-12456	50	110	50	95	26	65	50	80	170	130	220	10,1	125
	C-12470	63	140	63	112	33	75	63	100	210	160	270	15,4	200
	C-12490	80	170	80	140	39	95	80	125	250	210	320	30	320
	C-124100	100	210	100	180	45	120	100	160	315	260	400	60,2	500

Note: Pivot pin and seeger are included in the supply
Supplied with threaded holes for pivot pin locking plate (not included)

C-134 - Clevis bracket in angle to DIN 24556 or ISO 8133 with additional machining for dimension CO	Code	CF	CG	CO	CP	FM	FO	GL	HB	KC	LG	LJ	LO	RE	SR	TA	UJ	UK	Mass	Max load
		K7	+0,1V-0,3	H9	h14	js13	FO	JS13	H13			min	max	js13	max	js13	max	max	max	[kg]
	C-13425	12	10	10	30	40	16	46	9	3,3	28	29	56	55	12	40	75	60	0,52	8
	C-13432	16	14	16	40	50	18	61	11	4,3	37	38	74	70	16	55	95	80	1,05	12,5
	C-13440	20	16	16	50	55	20	64	13,5	4,3	39	40	80	85	20	58	120	90	1,72	20
	C-13450	25	20	25	60	65	22	78	15,5	5,4	48	49	98	100	25	70	140	110	2,72	32
	C-13463	30	22	25	70	85	24	97	17,5	5,4	62	63	120	115	30	90	160	135	5,15	50
	C-13480	40	28	36	80	100	24	123	22	8,4	72	73	148	135	40	120	190	170	9,3	80
	C-134100	50	35	36	100	125	35	155	30	8,4	90	92	190	170	50	145	240	215	18,3	125
	C-134125	60	44	50	120	150	35	187	39	11,4	108	110	225	200	60	185	270	260	35	200
	C-134160	80	55	50	160	190	35	255	45	11,4	140	142	295	240	80	260	320	340	63	320
	C-134200	100	70	63	200	210	35	285	48	12,4	150	152	335	300	100	300	400	400	109	500

Note: Pivot pin with locking plate is included in the supply

C-144 - Eye bracket to ISO 8133	Code	CK	AA	E	EM	FL	HB	LE	MR	R	Mass	Max load
		H9		max	h13	js13	H13	min	max	js13	[kg]	static [kN]
	C-14425	10	40	40	12	23	5,5	13	12	28,3	0,3	8
	C-14432	12	47	46	16	29	6,6	19	17	33,2	0,45	12
	C-14440	14	59	65	20	29	9	19	17	41,7	0,9	20
	C-14450	20	74	79	30	48	13,5	32	29	52,3	1,3	32
	C-14463	20	91	91	30	48	13,5	32	29	64,3	1,9	50
	C-14480	28	117	118	40	59	17,5	39	34	82,7	4	80
	C-144100	36	137	132	50	79	17,5	54	50	96,9	6,25	125
	C-144125	45	178	174	60	87	24	57	53	125,9	11,4	200
	C-144160	56	219	215	70	103	30	63	59	154,9	20,8	320
	C-144200	70	269	256	80	132	33	82	78	190,2	38,8	500

C-154 - Trunnion bracket (for cylinders with mounting styles G,H and L) to ISO 8132	Code	CR	CO	FH	FK	FN	FS	HB	KC	NH	TH	UL	Mass	Max load
		H7	N9	max	JS12	max	js13	H13	0/+0,3	max	js13	max	[kg]	static [kN]
	C-15425	12	10	25	34	50	8	9	3,3	17	40	63	0,46	8
	C-15432	16	16	30	40	60	10	11	4,3	21	50	80	0,83	12,5
	C-15440	20	16	38	45	70	10	11	4,3	21	60	90	1,21	20
	C-15450	25	25	45	55	80	12	13,5	5,4	26	80	110	2,15	32
	C-15463	32	25	52	65	100	15	17,5	5,4	33	110	150	4,63	50
	C-15480	40	36	60	76	120	16	22	8,4	41	125	170	7,78	80
	C-154100	50	36	75	95	140	20	26	8,4	51	160	210	14,3	125
	C-154125	63	50	85	112	180	25	33	11,4	61	200	265	23,4	200
	C-154160	80	50	112	140	220	31	39	11,4	81	250	325	53,1	320
	C-154200 (1)	100	63	150	200	300	42	52	12,4	101	320	410	112	500





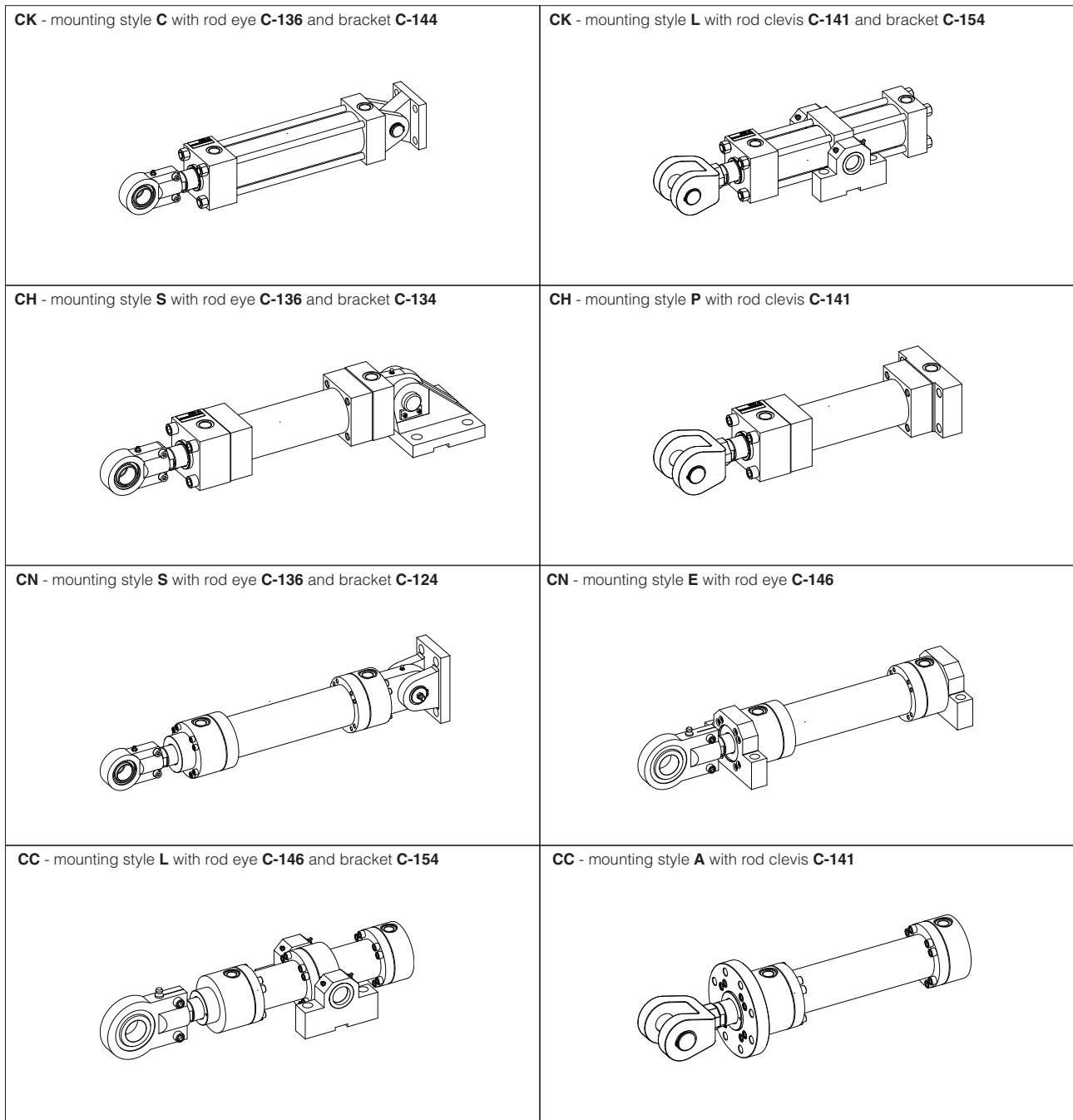



Note: The code includes two trunnion brackets
(1) To ISO 8133

4 EXAMPLES OF ATTACHMENTS



5 SURFACE TREATMENT

Some attachments are provided with additional surface treatment to increase the corrosion resistance (24h in neutral salt spray), see table below for details. All the attachments, except pivot pin C-145, can be supplied with standard painting RAL 9007 (200h in neutral salt spray) selecting option **-V**, special painting are available on request.

Code	Surface treatment	Code	Surface treatment
 C-136 or C-146	No treatment	 C-124	No treatment
 C-141	No treatment	 C-134	No treatment
 C-151	Black phosphate	 C-144	Black phosphate
 C-145	Black phosphate	 C-154	No treatment